



FIRST CHOICE
FOR SMALL & MEDIUM
HYDROPOWER PLANTS

Technology

Single source

Relationship

**On time
delivery**

**Small
Hydro power**

245 projects

executed across 12 countries

Economical

561
units delivered

**Medium
Hydro power**

300+
employees

From water to wire

45+ years
of global Hydro experience

5,000+ MW
capacity served

FLOVEL believes in customer delight. With its technological expertise and senior management's commitment it brings the Small & Medium Hydro projects alive on time, with maximum performance and minimum downtime. Our customers are glad to have chosen FLOVEL for their Hydropower project.



SMALL & MEDIUM HYDROPOWER OPPORTUNITIES

HYDROPOWER OFFERS
NEW OPPORTUNITIES
FOR THE WORLD.

Small & Medium Hydropower plants are a low cost and environment friendly source of electrical energy. An area with large untapped potential, is available in most part of the world. The technology to exploit this potential is well proven and reliable.

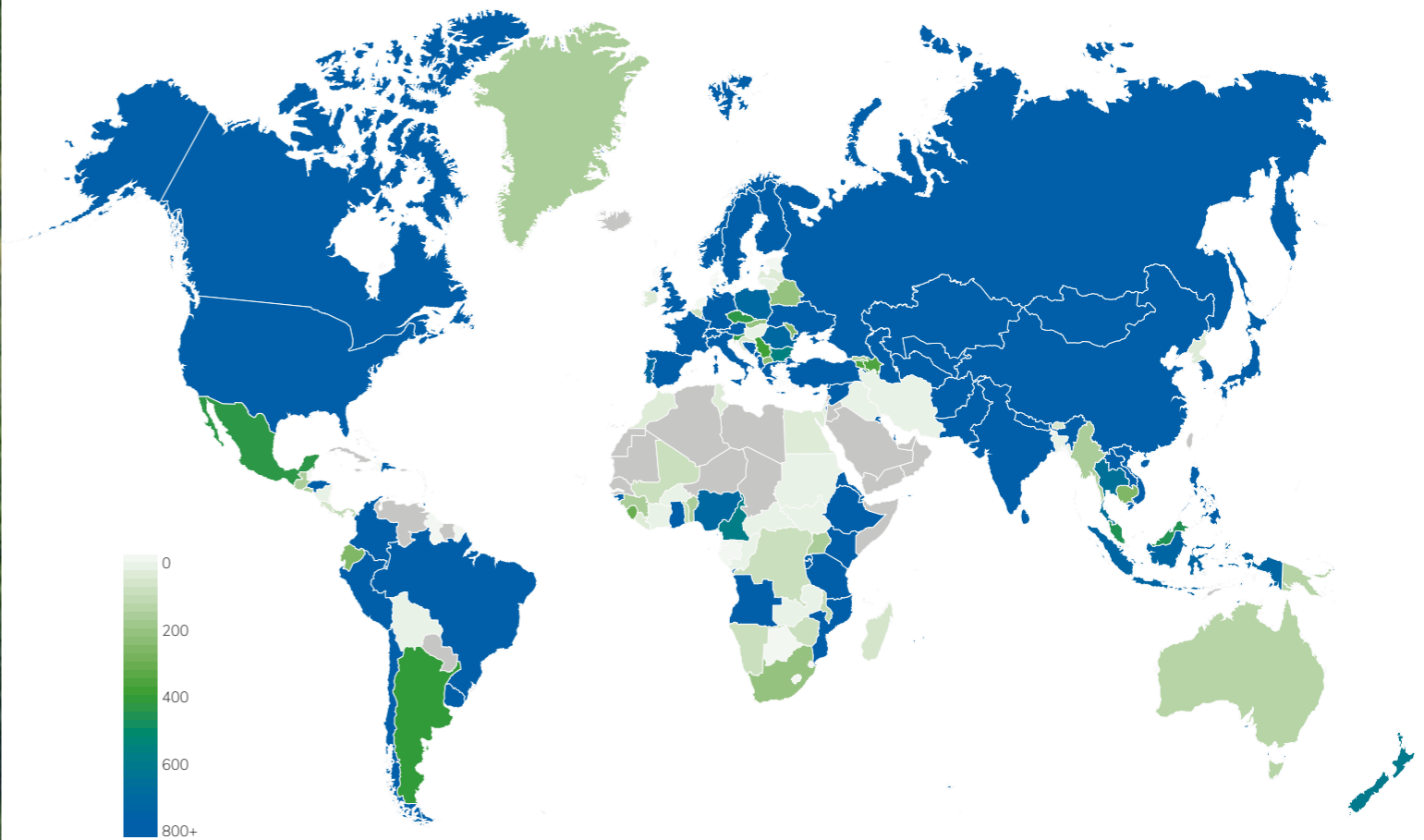

Identified SHP potential by country (MW).
Source: World Small Hydropower Development Report 2016.



“OUR VISION IS TO BE A TECHNOLOGY LEADER AND TO BE AMONGST THE TOP HYDROPOWER EQUIPMENT MANUFACTURERS GLOBALLY, BY LEVERAGING TECHNOLOGICAL AND COMMERCIAL ACUMEN, TO EXCEED CUSTOMER EXPECTATION AND TO BE THE MOST RESPECTED BRAND.”



As manufacturer of Hydraulic Turbines and Valves, we are a full line supplier of Electromechanical Equipment & Services for Small & Medium Hydropower projects and aftermarket services for the existing power plants.

We provide Turnkey Hydropower Solutions – with cohesive integration of design, manufacturing, execution and service support. With our incessant focus on quality and total customer satisfaction, we have set new benchmarks in 'implementation finesse' that have translated into sustainable benefits for our customers.

ADVANTAGE ON YOUR SIDE

CONTRACTING

- » No hidden clauses
- » Dedicated point of contact

SOLUTION DEVELOPMENT

- » Collaborative approach
- » Fully equipped, technologically advanced design facilities

PRODUCT MANUFACTURING

- » State-of-the-art manufacturing facilities
- » Global standard quality checks & processes

PROJECT IMPLEMENTATION

- » On time as guaranteed delivery
- » Faster response time to issues

POST IMPLEMENTATION

- » High plant availability
- » Quick response to any issue

- Single source responsibility
- Senior management involvement
- Safe and high-performance products
- Within budget, on time delivery
- Lower Cost of Ownership translating into higher returns

Profits & Peace of Mind

Manufacturing facility



FLOVEL is certified for Integrated Management Systems, which includes ISO:9001, ISO:14001, OHSAS 18001 and CE Certification



WATER TO WIRE PROGRAM FOR BEST RETURN ON INVESTMENT

OPTIMUM SOLUTIONS UP TO 60 MW UNITS

Each Hydropower plant has unique challenges. FLOVEL helps turn these challenges into opportunities. FLOVEL works collaboratively, brings new ideas to the project design to result in a safe plant with higher productivity. FLOVEL has the knack of delivering projects on time. Optimal technology deployment, time-bound execution and quick response are integral to FLOVEL's functioning.

FACTS

- » Integrated solutions with minimized interfaces
- » Minimized civil construction cost
- » High Quality
- » Short delivery time
- » Cost effectiveness
- » High performance & reliability
- » Environment friendly solutions
- » Workshop assembly for reduced erection time
- » Fast commissioning of overall systems, training of operating and maintenance staff
- » After sales service

FEATURES

- » Single source responsibility
- » Total power plant design / integration
- » Technical & Commercial optimisation
- » Complete erection, testing & commissioning
- » Low operating cost

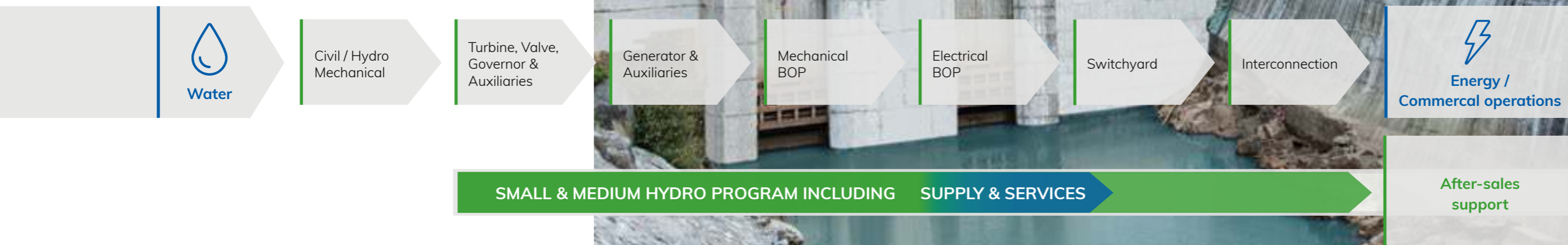
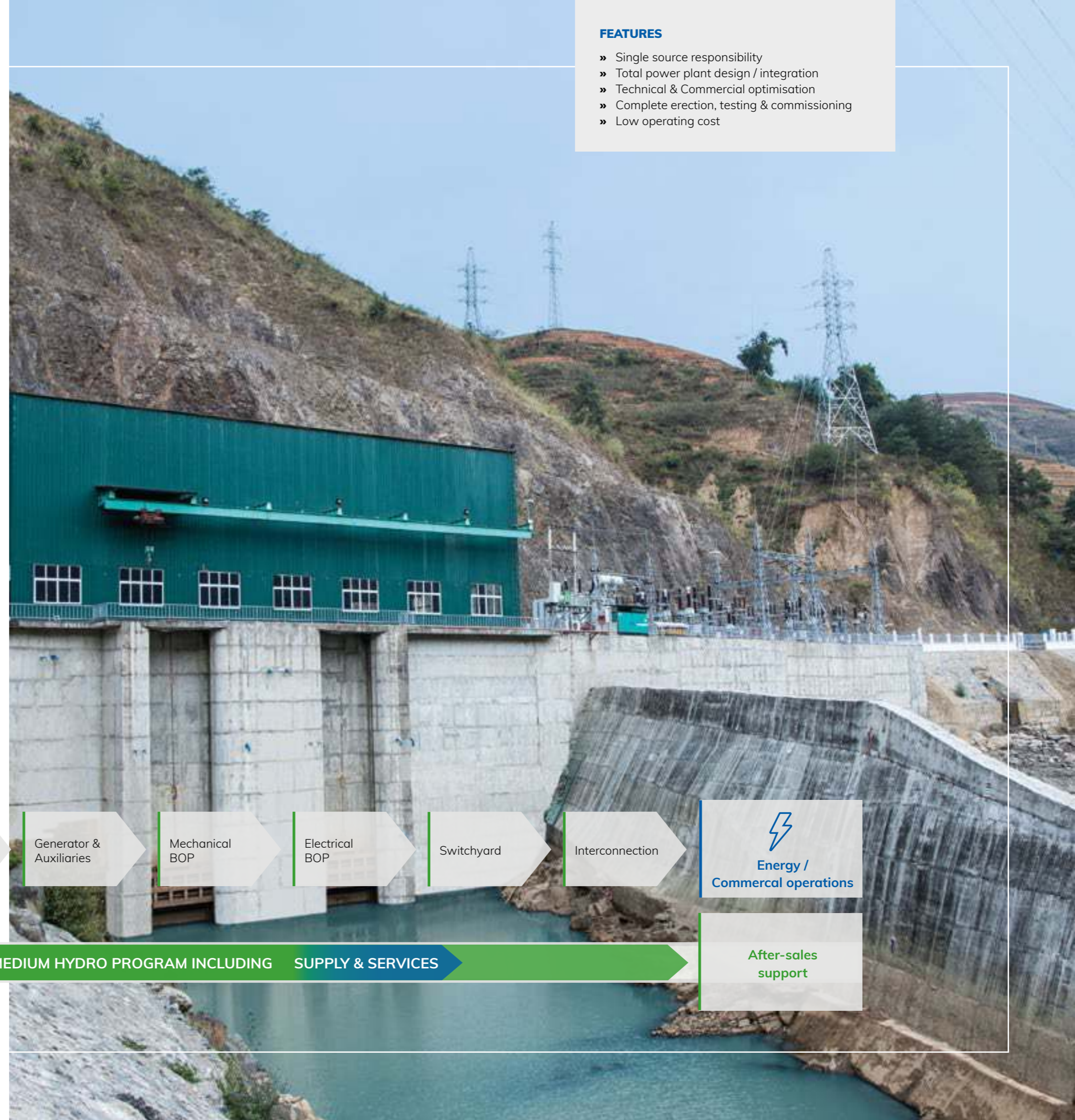

SMALL & MEDIUM HYDRO PROGRAM INCLUDING SUPPLY & SERVICES

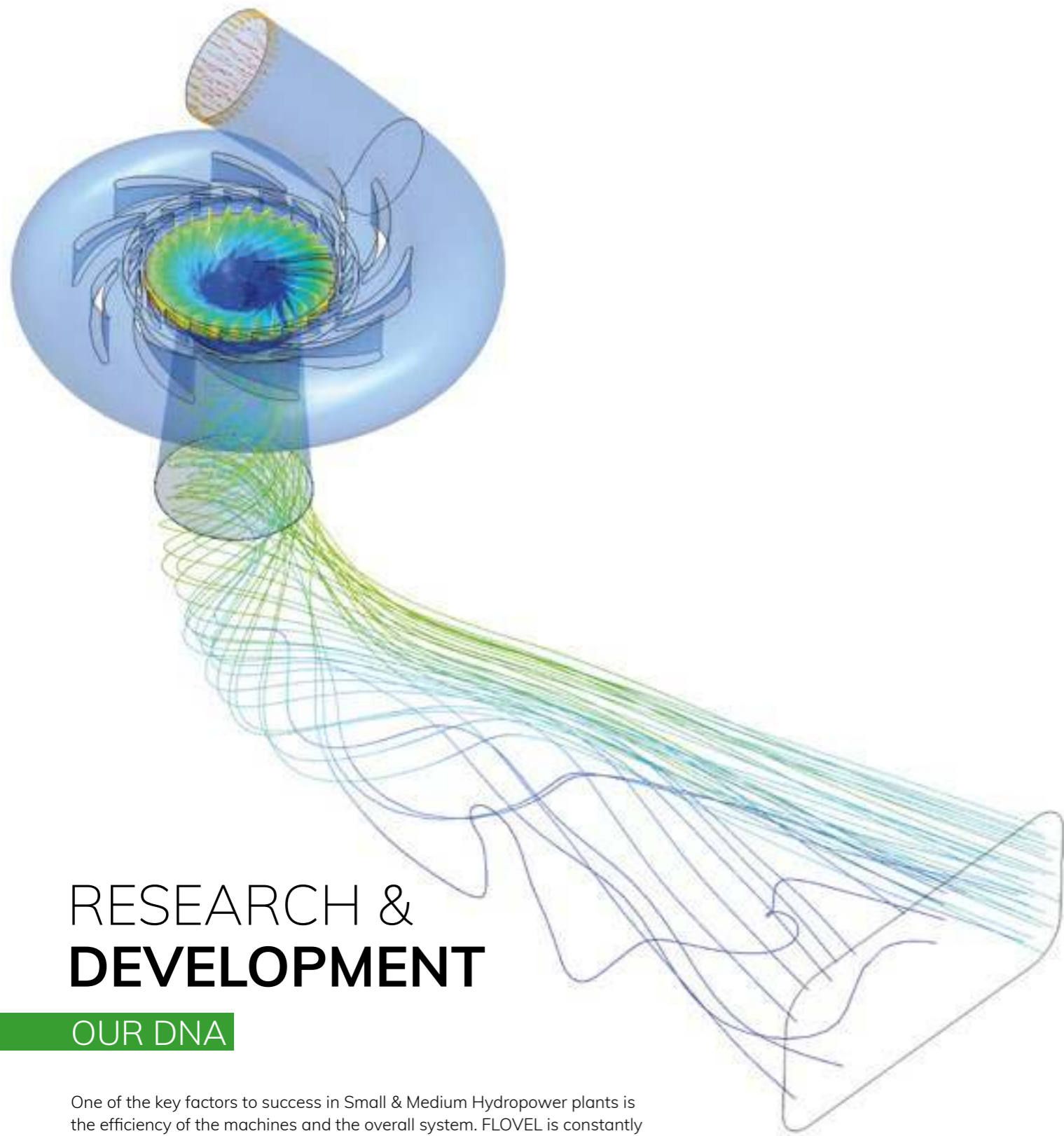

RESEARCH & DEVELOPMENT

OUR DNA

One of the key factors to success in Small & Medium Hydropower plants is the efficiency of the machines and the overall system. FLOVEL is constantly improving the efficiency of its equipment and technologies through continuous Research & Development efforts.



MODEL TEST

Should the customer require a model test to be performed, FLOVEL is equipped to have a model test conducted at an accredited / independent model testing laboratory.

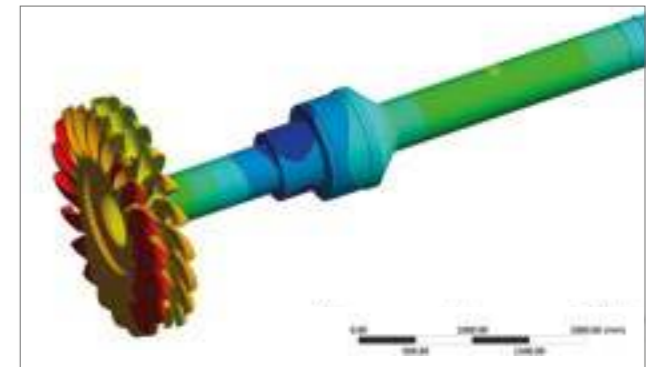

FEM

Finite element method (FEM) tools for calculating stresses, strains and deflections in components of a hydraulic turbine.

KARSBOL CONSULTING AB., SWEDEN

» Karsbol is a world leading technology provider for hydraulic turbines based out of Sweden. Karsbol specialises in research and development and design of Pelton, Francis, Kaplan and Axial Flow units.

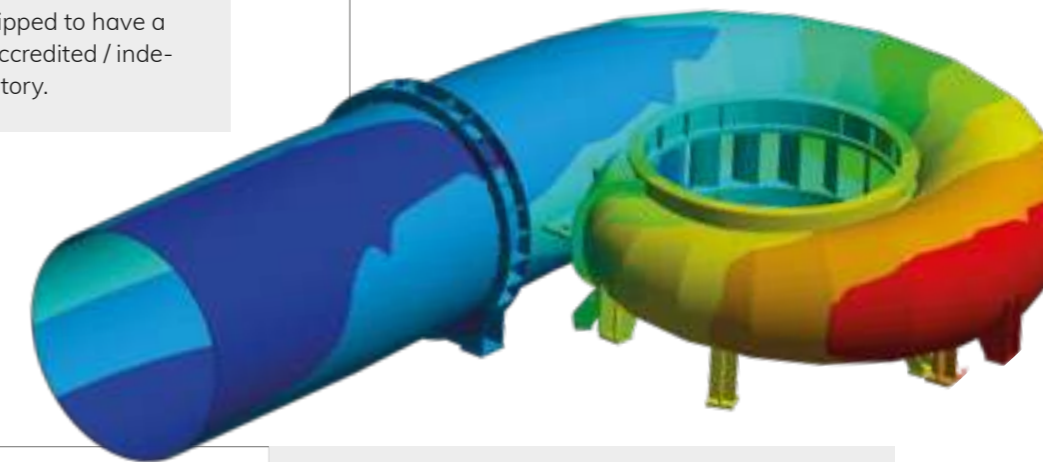

CFD

Tools to accurately predict flow characteristic. CFD is used to improve hydraulic design of turbine water passages, including the runner and static components. For renovation projects CFD is a very important tool for improving turbine output, efficiency and cavitation characteristics.

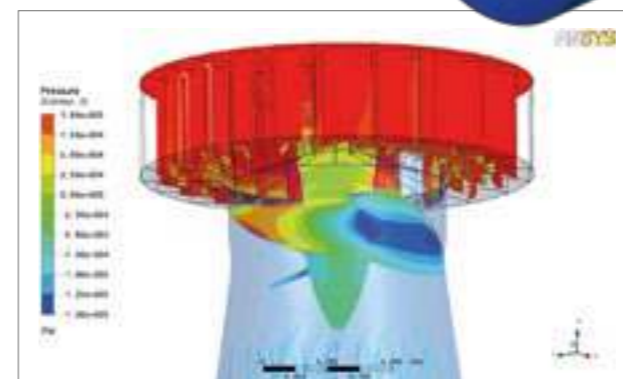



QUALITY MADE WITH PASSION

PRODUCT OVERVIEW

FLOVEL is manufacturing complete range of Hydraulic turbines (Pelton, Francis, Kaplan, Axial flow units) upto 1,000 meter head and 100 m³/sec discharge. These turbines are manufactured to the highest quality standard and designed for optimal performance and high reliability.

TURBINES

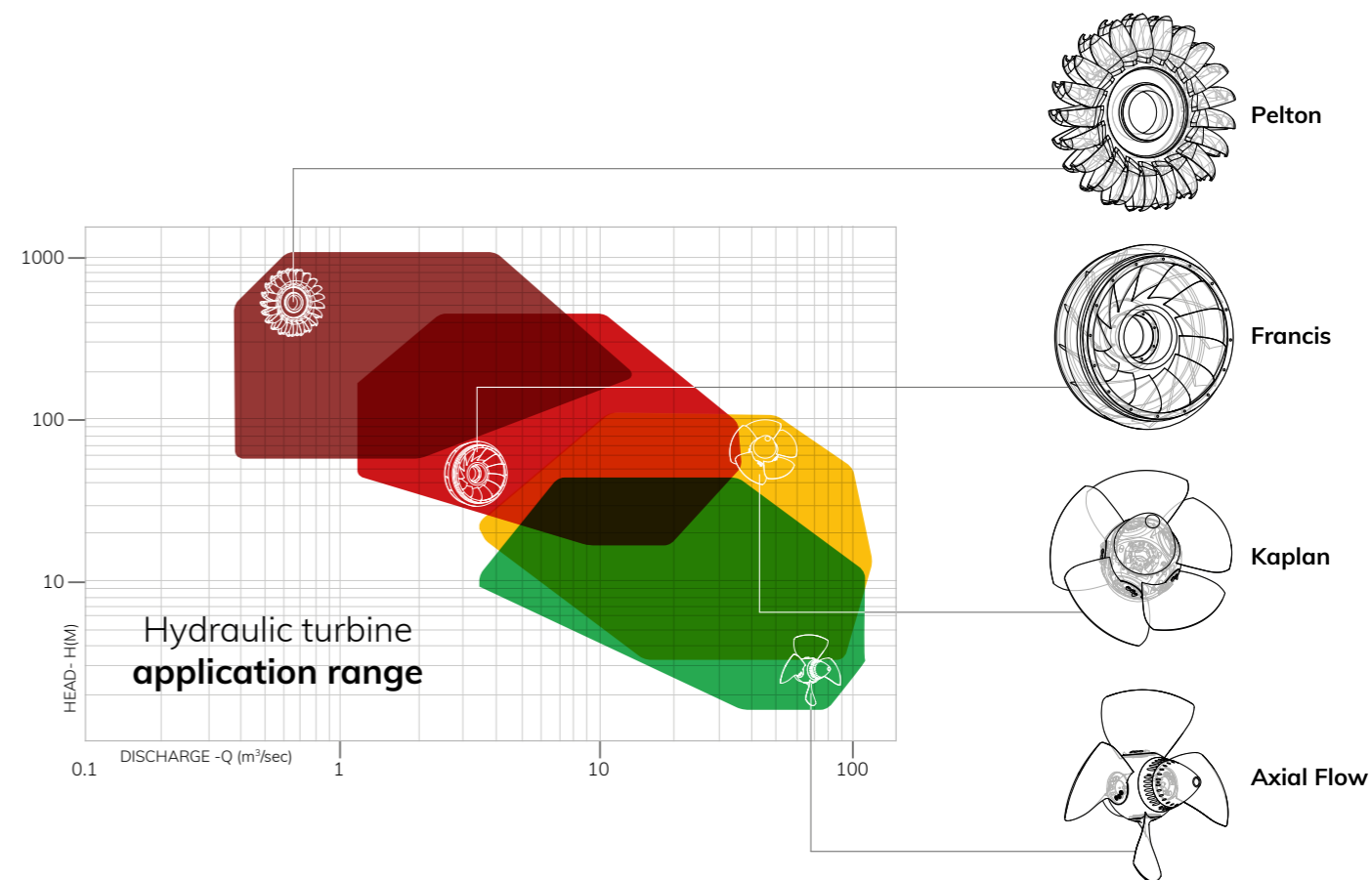

BUSINESS AREAS

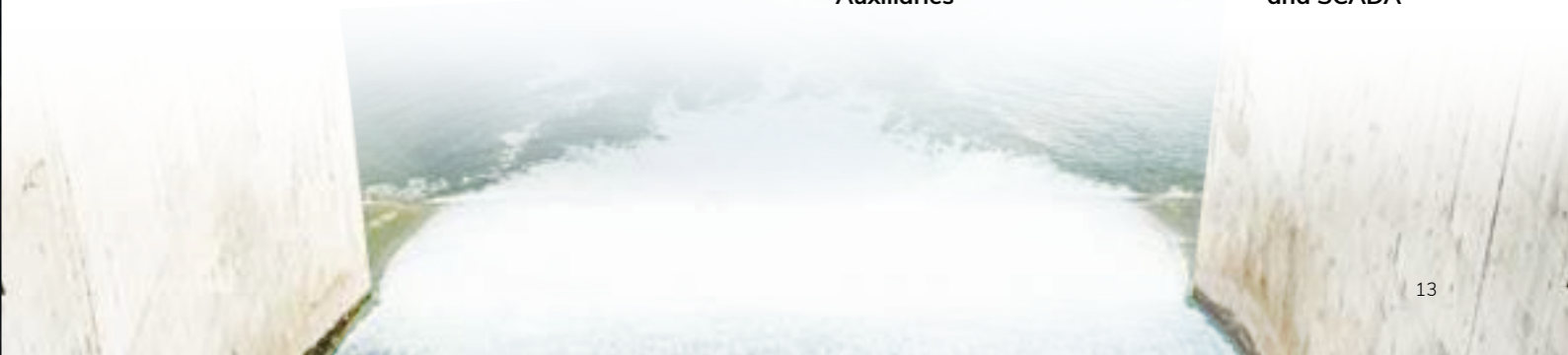
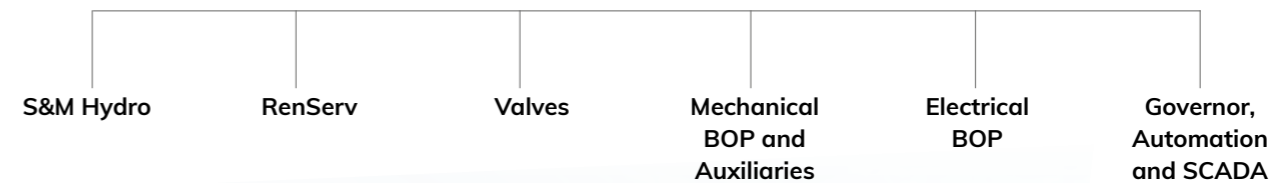

PELTON TURBINES for high head applications

Pelton Turbine is an impulse turbine used primarily for applications with high head and small flows. FLOVEL's Pelton turbines are based on decades of know-how and state-of-the-art technology. These Pelton turbines guarantee the highest operating efficiency and reliability.

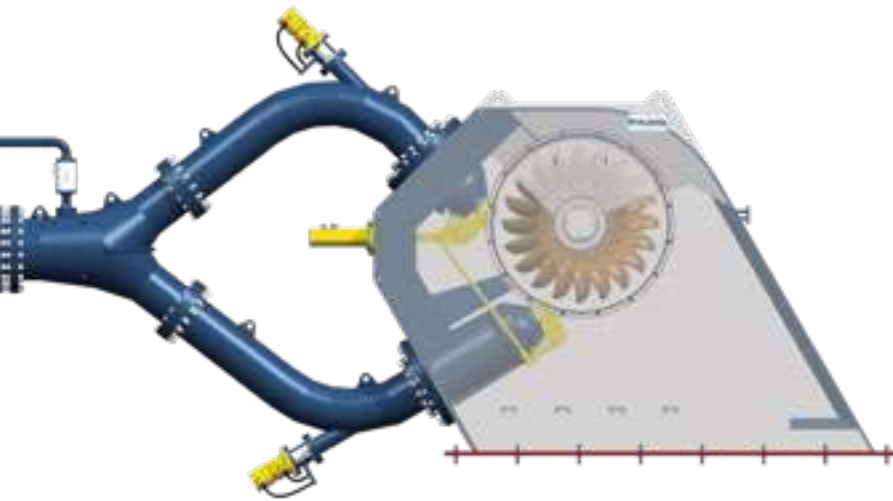

FEATURES

- » Fully Forged or Cast runner
- » Runner mounted on extended shaft of the generator
- » Full unit assembled in factory and shop tested
- » Internal or external Servomotor options
- » Simple interface with civil works
- » Guarantees for efficiency based on model test

Application Range:

- » Heads up to 1,000 Meters
- » Horizontal axis (1 to 3 jets)
- » Vertical axis (2 to 6 jets)

KAPLAN TURBINES for low head applications

Kaplan Turbine is a reaction turbine used primarily for applications with low head and large flows. FLOVEL's Kaplan turbines are based on decades of know-how and state-of-the-art technology. These Kaplan turbines guarantee the highest operating efficiency and reliability.

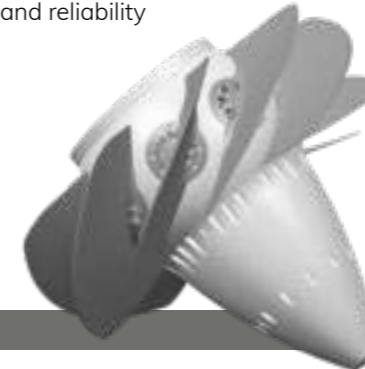

FEATURES

- » Oil free runner hubs
- » Internal or external Servomotor option
- » Maintenance free water-lubricated guide bearing
- » Blade dismantling without runner removal
- » Library of 20 models available to choose from
- » Guarantees for output, efficiency and cavitation based on model test

Application Range:

- » Heads up to 70 Meters
- » Runners with 3 to 8 blades
- » Double or Single regulated
- » With or without Gearbox
- » Steel, Concrete Spiral or Syphon Intake

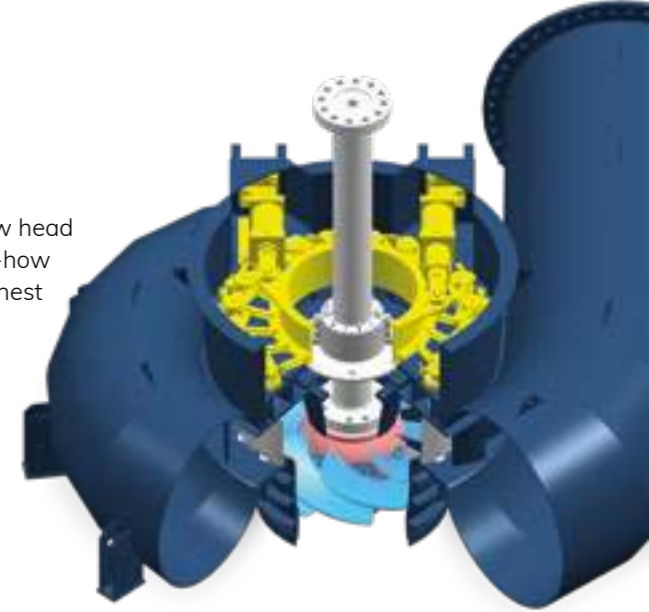

FRANCIS TURBINES for medium head applications

Francis Turbine is a reaction turbine used primarily for applications with medium head and large flows. FLOVEL's Francis turbines are based on decades of know-how and state-of-the-art-technology. These Francis turbines guarantee the highest operating efficiency and reliability.



FEATURES

- » Weld fabricated or Forged runners
- » Library of 40 models available to choose from
- » Guarantees for output, efficiency and cavitation based on model test
- » Runner mounted on extended shaft of the generator
- » Common base frame concept for horizontal units

Application Range:

- » Heads up to 450 Meters
- » Horizontal or Vertical axis
- » Steel or Concrete Spiral

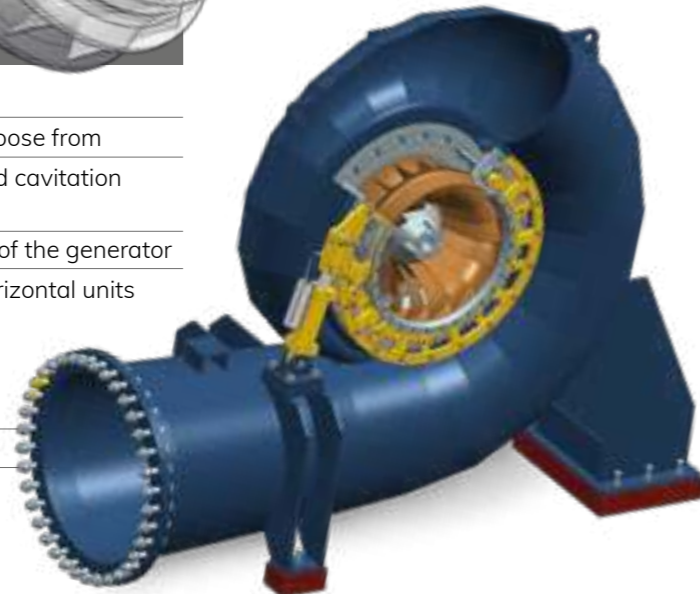

AXIAL FLOW TURBINES for very low head applications

Axial Flow units are used primarily for applications with low head and large flows. FLOVEL's Axial Flow units are based on decades of know-how and state-of-the-art-technology. These Axial Flow units guarantee the highest operating efficiency and reliability.

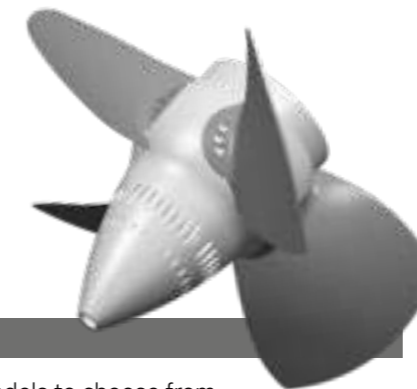

FEATURES

- » Library of 20 models to choose from
- » Oil free runner hubs
- » Internal or external Servomotor option
- » Maintenance free water-lubricated guide bearing
- » Blade dismantling without runner removal
- » Guarantees for output, efficiency and cavitation based on model test

Application Range:

- » Heads up to 35 Meters
- » Runners with 3 to 6 blades
- » Double or Single regulated
- » With or without Gearbox
- » Horizontal, Diagonal or Vertical orientation

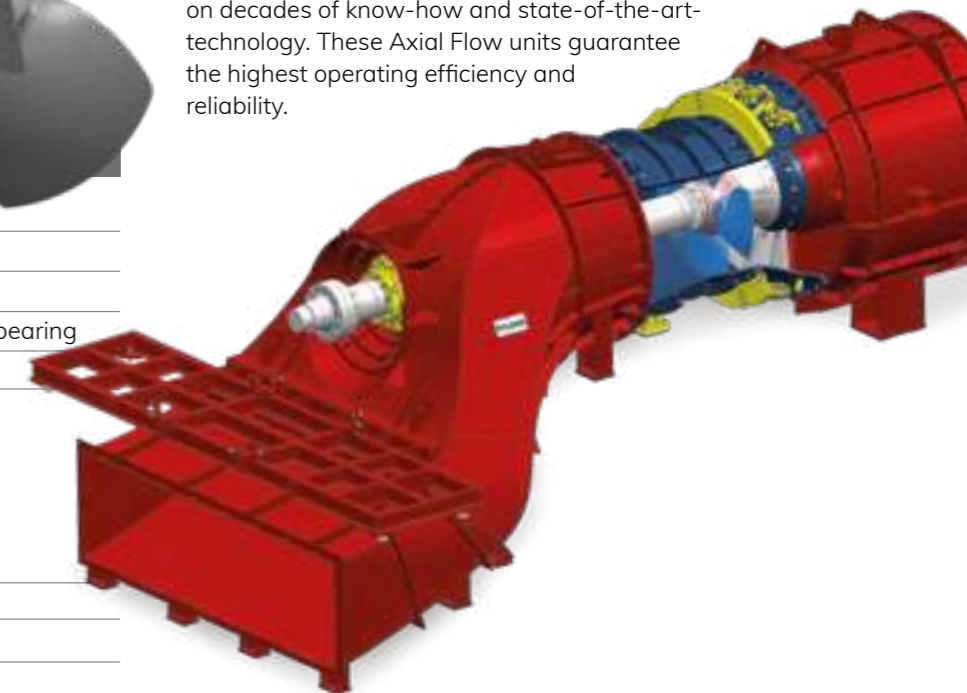



VALVES

FLOVEL manufactures full range of Valves under its joint venture with TB Hydro, Poland. These valves are manufactured by JV company TB Hydro Flovel Valves Private Limited.

TYPES

- » Butterfly Valves
- » Spherical / Ball Valves
- » Pressure Relief Valves etc.



MECHANICAL BOP & AUXILIARIES

SCOPE

- » Oil Pressure System for turbine, MIV & PPV
- » Cooling Water System
- » Drainage System
- » Dewatering System
- » Crane
- » Fire Fighting System
- » Ventilation & Air Conditioning System
- » Compressed Air System
- » Bearing Lubrication System
- » Oil Filtration System
- » Flow & Level Measurement System
- » Vibration Measurement System

GENERATOR, AVR & AUXILIARIES

- » Control & Protection System
- » Generator Transformers
- » AC-DC distribution
- » LV and MV-switchgear
- » Bus Ducts
- » Cables, HV, LV, Control & instrumentation
- » Outdoor Switchyard equipment
- » Integration of automation system, governing system, electrical system, mechanical system etc.
- » Digital automation of mechanical, electrical, LV system & other auxiliaries



ELECTRICAL BOP

We deliver tailor-made systems as per customer requirements. Our solutions are safe, reliable and provide cost-effective operation. We are a single source provider ensuring complete service and seamless availability for your hydropower plant and all its components and systems. Our long-term process know-how and control system expertise in hydropower applications coupled with high efficiencies and post implementation service brings the Advantage on your side.

GOVERNOR, AUTOMATION & SCADA



DIGITAL GOVERNOR TECHNOLOGY

- » Integration of automation system, governing system, electrical system, mechanical system etc.
- » Digital automation of mechanical, electrical, LV system & other auxiliaries.



A GOOD JOB FOR AN EXCITING MARKET

FLOVEL's key personnel and coworkers in all functions are among the best in the country with right educational qualifications and vast experience in their respective field and trained at various international locations to work to global standards. FLOVEL has a total strength of more than 300 people who by their knowledge, experience and innovative approach assure a competitive edge to the market and to a long term development of the company.

**OUR MANUFACTURING FACILITIES.
WHERE EXCELLENCE IS MADE.**



Khao Mang, Vietnam

Type of Turbines: Vertical Francis
Rated Head: 109.00 m
Installed Capacity: 2 x 15,000 kW



Lebak Barang, Indonesia

Type of Turbines: Horizontal Francis
Rated Head: 50.39 m
Installed Capacity: 3 x 2,673 kW

Akinci - I/II, Turkey
Type of Turbines: 'PIT' Type – Axial Flow
Rated Head: 6.40 m
Installed Capacity: 4 x 3,600 kW



Hua Chang, Vietnam

Type of Turbines: Horizontal Pelton 2 Jets
Rated Head: 236.42 m
Installed Capacity: 2 x 5,432 kW

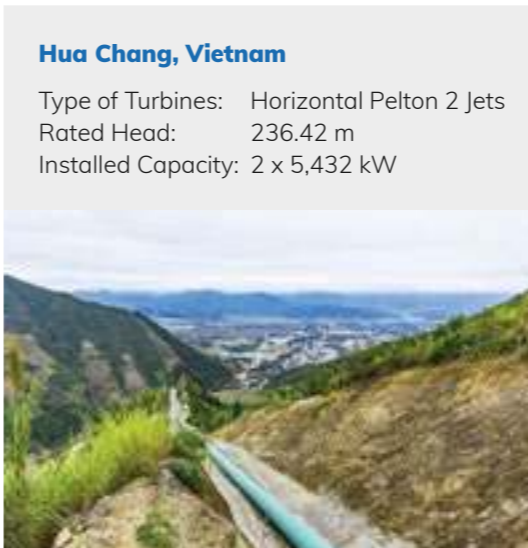

Saray, Turkey

Type of Turbines: Vertical Full Kaplan
Rated Head: 24.87 m
Installed Capacity: 2 x 6,750 kW



Bac Na, Vietnam

Type of Turbines: Vertical Pelton 4 Jets
Rated Head: 279.00 m
Installed Capacity: 2 x 9,350 kW

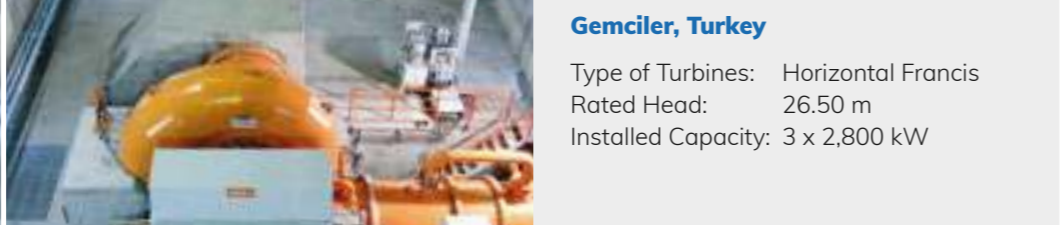

Gemciler, Turkey

Type of Turbines: Horizontal Francis
Rated Head: 26.50 m
Installed Capacity: 3 x 2,800 kW



Noong Phai, Vietnam

Type of Turbines: Vertical Francis
Rated Head: 87.50 m
Installed Capacity: 2 x 11,600 kW



Sarbari – II, India

Type of Turbines: Horizontal Pelton 2 Jets
Rated Head: 189.65 m
Installed Capacity: 2 x 3,375 kW

Ghatte Khola, Nepal

Type of Turbines: Horizontal Pelton 2 Jets
Rated Head: 322.50 m
Installed Capacity: 2 x 2,750 kW



Khlong Tron, Thailand

Type of Turbines: Horizontal Francis
Rated Head: 30.55 m
Installed Capacity: 2 x 1,250 kW

Nam Sana, Laos

Type of Turbines: Horizontal Francis
Rated Head: 145.77 m
Installed Capacity: 3 x 5,159 kW



FURTHER PROJECTS

Ambarlik, Turkey

Type of Turbines: Horizontal Pelton 3 Jets
Rated Head: 247.84 m
Installed Capacity: 2 x 4,500 kW

Brua, India

Type of Turbines: Horizontal Pelton 2 Jets
Rated Head: 572.74 m
Installed Capacity: 2 x 4,950 kW

Buseruka, Uganda

Type of Turbines: Horizontal Pelton 2 Jets
Rated Head: 316.00 m
Installed Capacity: 3 x 3,600 kW

Eglenç – I, Turkey

Type of Turbines: Vertical Francis
Rated Head: 276.23 m
Installed Capacity: 2 x 18,060 kW + 1 x 8,663 kW

Eglenç – II, Turkey

Type of Turbines: Horizontal Francis
Rated Head: 168.90 m
Installed Capacity: 2 x 11,025 kW + 1 x 5,250 kW

Hang Dong B, Vietnam

Type of Turbines: Horizontal Francis
Rated Head: 174.00 m
Installed Capacity: 2 x 17,500 kW

Nam Cum 4, Vietnam

Type of Turbines: Vertical Francis
Rated Head: 147.60 m
Installed Capacity: 2 x 27,000 kW

Ngoi Hut, Vietnam

Type of Turbines: Vertical Pelton 6 Jets
Rated Head: 322.50 m
Installed Capacity: 2 x 26,400 kW

Ngoi Hut 2A, Vietnam

Type of Turbines: Horizontal Francis
Rated Head: 91.03 m
Installed Capacity: 2 x 4,620 kW

Nilwande, India

Type of Turbines: Vertical Full Kaplan
Rated Head: 38.50 m
Installed Capacity: 2 x 4,200 kW

Omokawa, Japan

Type of Turbines: Horizontal Francis
Rated Head: 28.38 m
Installed Capacity: 1 x 110 kW

Perunthenaruvi, India

Type of Turbines: 'S' Type – Axial Flow
Rated Head: 17.33 m
Installed Capacity: 2 x 3,300 kW

Ranja Ala Dunadi, India

Type of Turbines: Horizontal Francis
Rated Head: 148.50 m
Installed Capacity: 2 x 8,250 kW

Segara 2, Indonesia

Type of Turbines: Horizontal Pelton 2 Jets
Rated Head: 140.30 m
Installed Capacity: 2 x 1,000 kW

Suoi Sap 1, Vietnam

Type of Turbines: Horizontal Francis
Rated Head: 100.38 m
Installed Capacity: 2 x 10,500 kW

Super Mai, Nepal

Type of Turbines: Horizontal Francis
Rated Head: 123.93 m
Installed Capacity: 2 x 4,290 kW

Trung Xuan, Vietnam

Type of Turbines: Vertical Full Kaplan
Rated Head: 17.50 m
Installed Capacity: 2 x 5,250 kW

Yan Tann Sien, Vietnam

Type of Turbines: Horizontal Pelton 2 Jets
Rated Head: 633.21 m
Installed Capacity: 2 x 9,750 kW



GET IN TOUCH



FLOVEL Energy Private Limited

15/3 Mathura Road, Faridabad – 121008,
Haryana, India
Phone: +91 129 4090600
Fax: +91 129 4090650
Email: contact@flovel.net

MANUFACTURING FACILITIES

FLOVEL Energy Private Limited

Mitrol – Deeghot Road
(Near Railway Crossing),
72 KM Stone, Delhi-Mathura Road,
District Palwal – 121102,
Haryana, India
Phone: +91 7082214002, 3 & 4

VIETNAM REPRESENTATIVE

EID / Harmony Power

Room 904, N07B1 Building,
Thanh Thai Street, Dich Vong,
Cau Giay District, Hanoi, Vietnam
Phone: +84915900666
Email: phamha.hydro@gmail.com

NEPAL REPRESENTATIVE

Marron Trading Pvt. Ltd.

Min Bhawan, Kathmandu, Nepal
Phone: +977 4106637, 4106638
Fax: +977 4106628
Email: marronmarket@wlink.com.np
muktinsharma@wlink.com.np

VALVES PARTNER

TB Hydro Flovel Valves Private Limited

15/3, Mathura Road,
Faridabad – 121008
Haryana, India
Phone: +91 129 4090600
Fax : +91 129 4090650
Email: contact@tfvalves.com
Web: www.tfvalves.com

INDONESIA REPRESENTATIVE

PT. Alam Daya Makmur

Arcamanik Residence, Kav 9,
Jalan Endahsari Arcamanik,
Bandung, Indonesia
Phone: +622 22018597
Fax : +622 22015263
Email: pt_adm@yahoo.com

COLOMBIA REPRESENTATIVE

B & V Ingenieria S.A.S.

Calle 25 Sur # 46 - 15,
Casa 118 / Envigado - Colombia.
Phone: +57 44442882
Email: gerencia@byv.com.co
Web: www.byv.com.co

LAOS REPRESENTATIVE

LEM Consultants Co. Ltd.

Ban Sokkham Unit 12,
Saysettha District, P.O. Box, 6480
Vientiane Capital, Lao PDR
Phone: +85621 461978
Email: somsavanh@lemconsultants.com

TURKEY REPRESENTATIVE

GLOBIA Consulting

Ataturk Mah. Vedat Gonyol Caddesi,
Yakut Sok, Zumrut Sitesi
Blok: 10 Daire1 34758 Atasehir,
Istanbul – Turkey
Phone: +90 216 548 1220
Fax: +90 216 548 1221
Email: bulent.biol@globia.com.tr
Web: www.globia.com.tr

CIS REPRESENTATIVE

JSC "IGHolding RUS"

Presnenskaya emb. 6, build.2,
Imperia Tower, Moscow 123371
Phone: +7 495 2222955
Email: info@ighrus.com

CENTRAL & SOUTH AMERICA

Cristhian Escobar

General Manager (Business Development)
FLOVEL Energy Private Limited
1C 20-10 Z.17 A19,
Guatemala City – 01017, Guatemala
Mobile: +502 54136030
Email: cristhian.escobar@flovel.net

PERU REPRESENTATIVE

Romicon Proyectos De Ingenieria SAC

Avenue José Gálvez Barrenechea
765 oficina 703, San Borja, Lima City
Republic of Peru
Phone: +51 1 3140668
Mobile: +51 996700317
Email: jroldan@romiconing.com